

LOAD-DEFLECTION CURVES

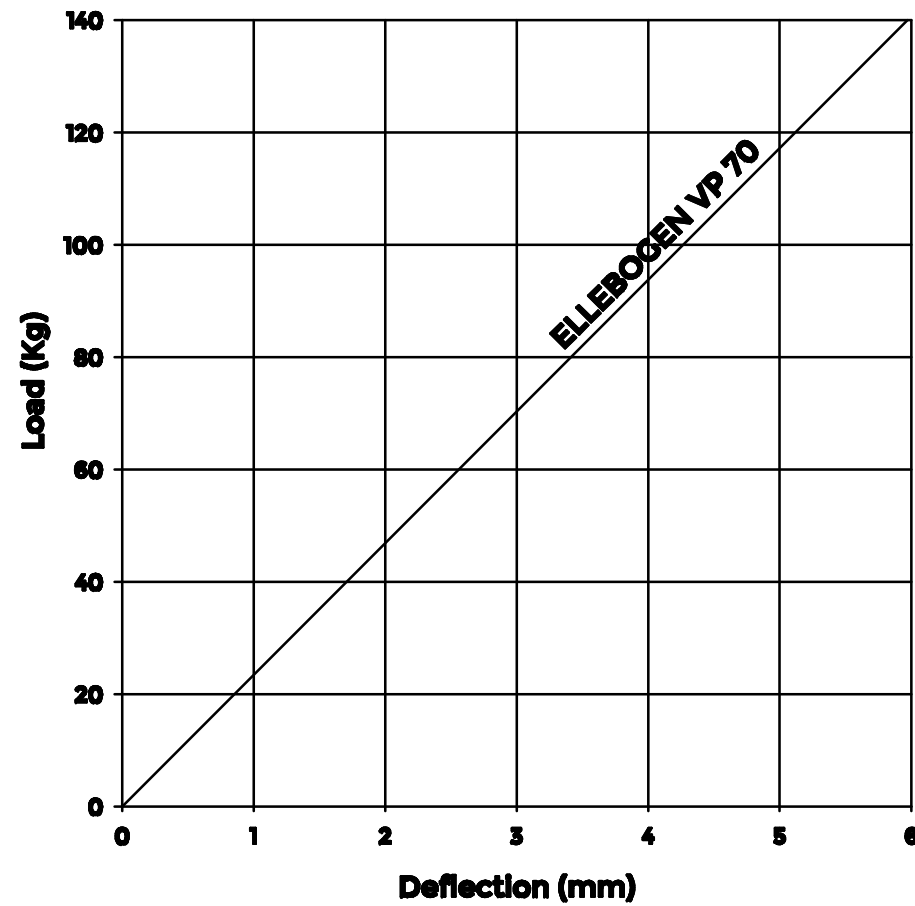

NATURAL FREQUENCY CURVES

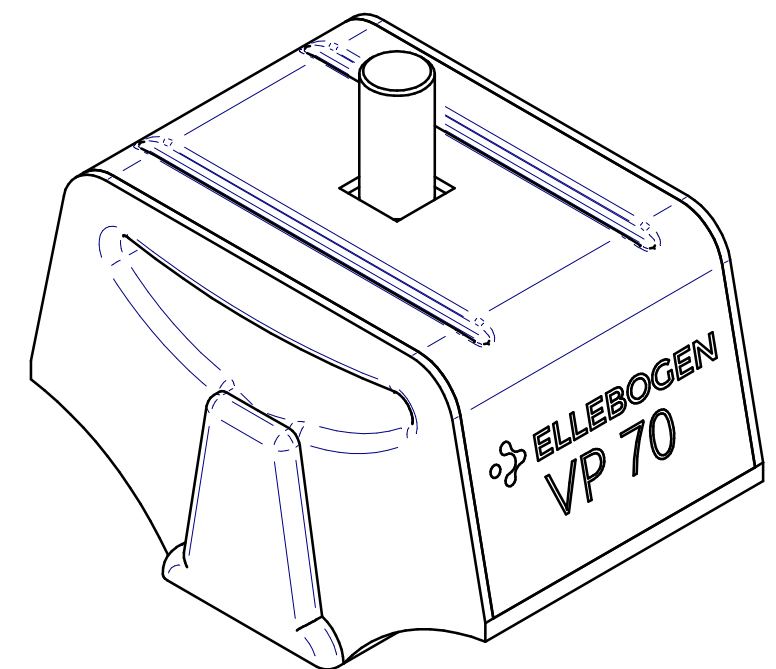
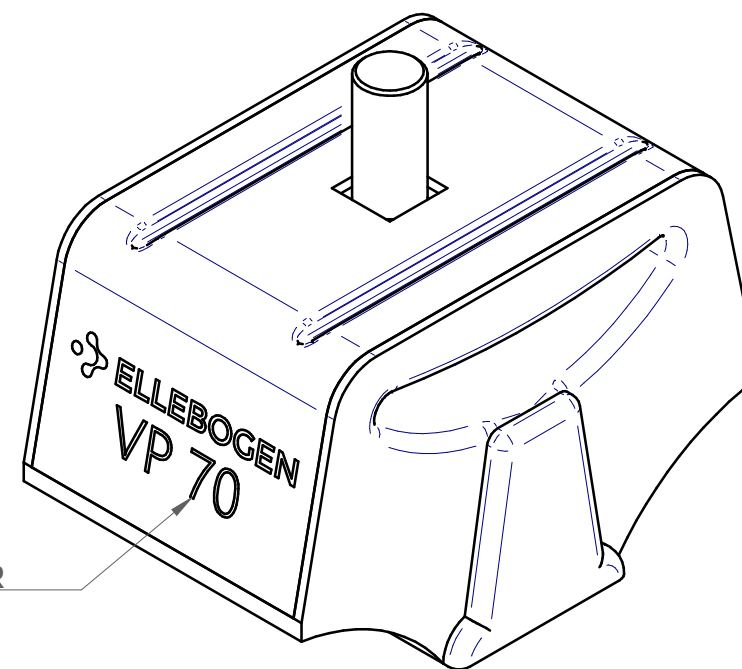
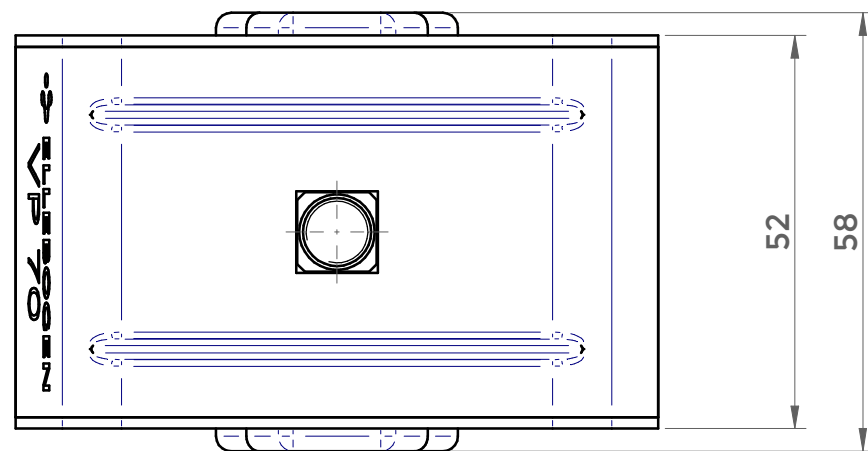
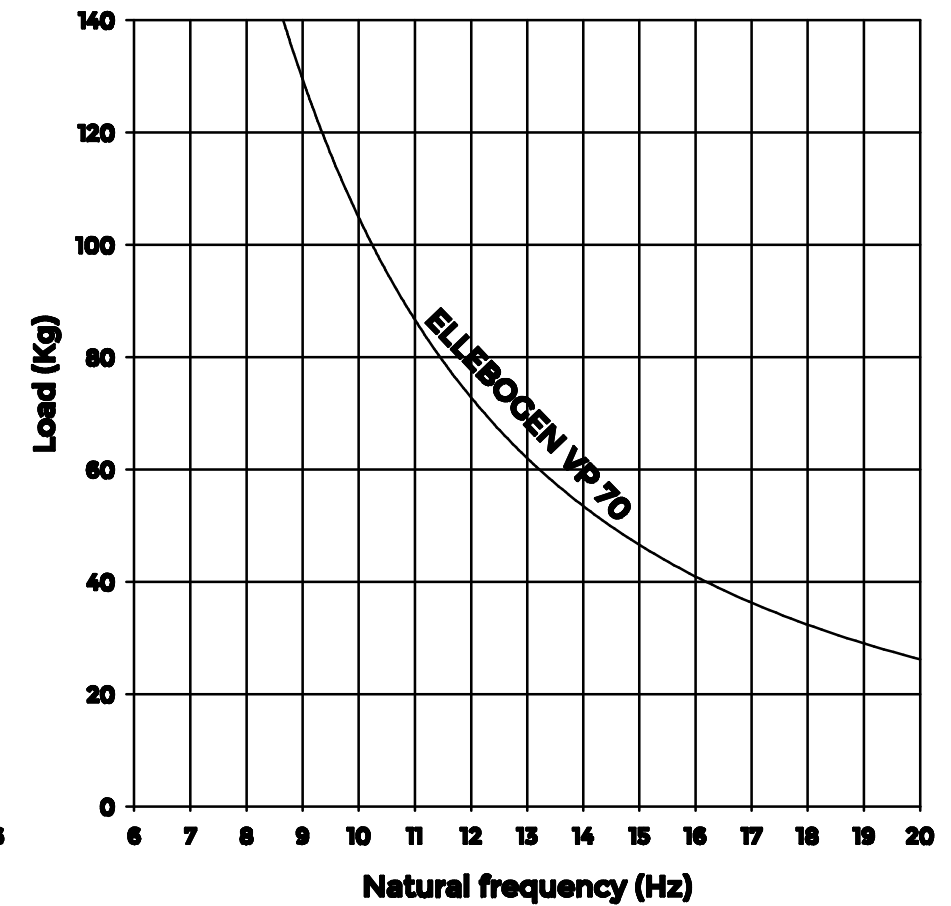

RECOMMENDED TIGHTENING TORQUE:

27 ~ 30 Nm
 2,7 ~ 3 kgf·m
 20 ~ 22 ft·lbs



ELLEBOGEN

PROJECTION:

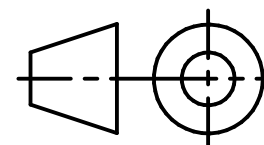

DESCRIPTION:

ELLEBOGEN VP 70 MARINE ENGINE MOUNT

REF. NO.:

858455

ESTIMATED WEIGHT:

0,543kg

REV.:

00

DRAWN:

R. E.

APPROVED:

I. J.

DATE:

28/11/2023

DATE:

28/11/2023

SCALE:

1:2

SHEET SIZE:

A3

GENERAL TOLERANCES ACC. TO ISO 2768-C

OVER (mm)	0,5	3	6	30	120	400	1000
UP TO (mm)	3	6	30	120	400	1000	2000
TOL. (mm)	±0,2	±0,3	±0,5	±0,8	±1,2	±2	±3

RUBBER TOLERANCES ACC. TO ISO 3302-M3

THIS DOCUMENT IS TO BE TREATED AS STRICTLY PRIVATE AND CONFIDENTIAL.

IT SHALL NOT BE DISCLOSED TO THIRD PARTIES WITHOUT PRIOR WRITTEN CONSENT.